

Simply long bulges:
 KNOLL bulge coiling device
 KNOLL bulge adjustment unit

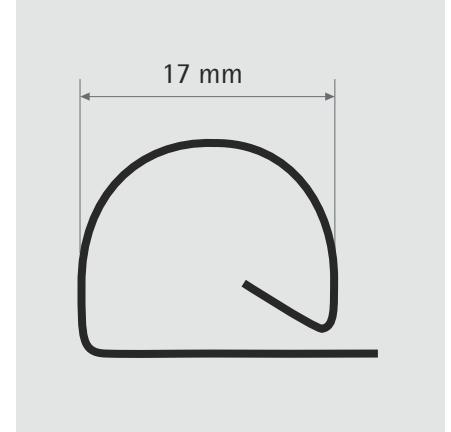

KNOLL bulge coiling device

You can easily produce long bulges with your folding machine with the KNOLL bulge coiling device.



KNOLL bulge adjustment unit

You adjust the fabricated bulge with the KNOLL bulge adjustment unit. By continuously increasing the contact pressure of the rollers, the bulged metal sheets are easily rounded into a convex or concave form. For Zn and Al, you even round the bulges without filling. The KNOLL bulge adjustment unit is also available with different roller diameters for the bulge turned with the bulge rod. For this please indicate the diameter of your bulge rod. Examples of applications: window sills, wall covering, refurbishment of old buildings, ...

TECHNICAL DATA

Metal thickness	Cu 0.7 mm
	Zn 0.7 mm
	Al 0.7 mm

Technical changes are in the interest of progress!
 © K.N.O.L.L e.K. 2022